

# Backstop to Prevent Reversal of Inclined Conveyor and Vertical Bucket Elevators

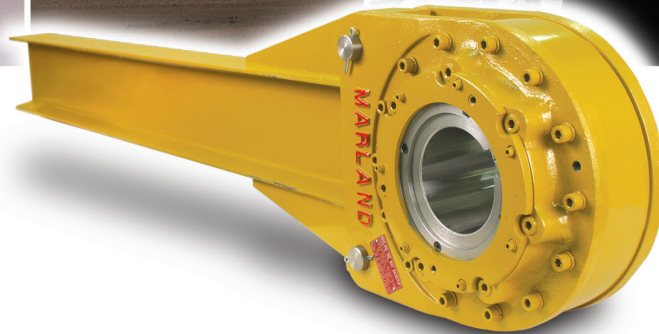

An Altra Industrial Motion Company

# The Company

## Marland

Since 1931, Marland has been producing backstops, clutches and clutch couplings. Marland products are based on a one-way clutch design, utilizing the principle of cylindrical rollers on inclined cam planes.

Marland Clutch also brings to the North American market a line of proven sprag type freewheel clutches. Marland utilizes the knowledge of its sister divisions, Stieber® of Germany and Formsprag® of the United States, to manufacture world class high performance sprag clutches in the United States.

## Marland Products

The Marland principle of rollers on inclined cam planes has proven its dependability for over 60 years in worldwide installations ranging from food processing plants to equipment used in steel mills and heavy mining industries. Proving the inherently long-life Marland design, the first two Marland clutch units installed in February, 1931, operated continuously for 31 years without repairs or replacements of any kind until the system became obsolete in 1962. Cam, rollers and outer race inspection showed them ready for additional years of service.

## The Need For Adequate Backstops

Positive protection against reverse torque runaways of inclined conveyor or elevated installations, and adequate provision for the safety of operational personnel, can be assured by considering the following:

1. The causes of reverse torque loading conditions.
2. The importance of installing backstops on low speed headshafts – where reverse torque loads originate.
3. Use of sound methods for selecting backstop sizes, based on many years of successful installations, rather than theoretical reverse torque calculations.
4. The basic design, operating principle and uniformly high torque capacity of Marland One-Way backstops.
5. The simple maintenance and lubrication requirement of the Marland design.



Marland Backstop Model BC-375MA being installed at taconite mining operation

## Illustration 1

Aluminum alloy cage with precision machined roller pockets results in controlled spacing and load sharing.

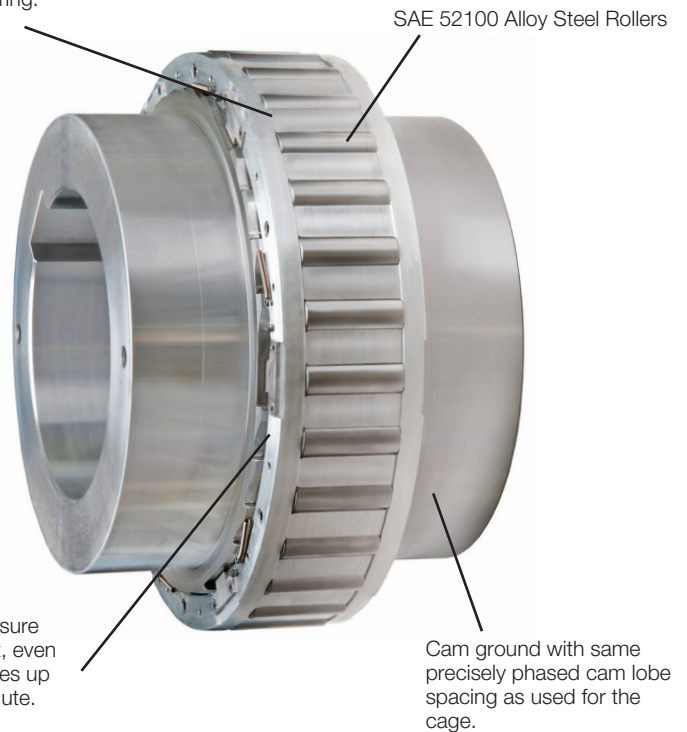

The quality management system necessary to support the Marland products has been certified to ISO 9001: 2008



Energizing springs insure positive engagement, even for rapid indexing rates up to 240 stroke per minute.

Cam ground with same precisely phased cam lobe spacing as used for the cage.

During freewheeling, (normal operation), the cam and roller assembly rotate with the headshaft as shown by the arrows in Illustration 2. The outer race is secured to stationary coverplates and "I" Beam Torque arm. An oil film wedges and separates the rollers from the outer race. This moves the rollers a few thousandths of an inch imparting relative angular motion between the roller cage and cam. This slight movement of the rollers into the deeper cam zones, with a clean lubricant film wedged between rollers and outer race, permits freewheeling without metal to metal contact.

When the conveyor decelerates and the cam subsequently comes to rest, the spring actuated roller cage, Illustration 1, has already positioned the rollers into the contact zone. All rollers have been positively guided to engage uniformly and maintain their relative positions accurately to assure uniform load distribution. The rollers then engage in compression between the precision ground, hardened cam plane surfaces and the inside diameter of the outer race. Relative motion between the cam and outer race is not required to engage rollers. When the backstop is in the "engaged" or "backstopping" condition, the cam, rollers, and outer race are relatively stationary and therefore, not subject to wear if used within normal tabulated rating.

## Mounting Details

Marland backstops are furnished with a clearance fit between the bore and shaft for easy field installations. The key should be a "drive tight" fit on the sides only. As a result a method of axial shaft retention is required for all backstops. The preferred method of accomplishing this is with the use of set collars which can be furnished by Marland upon request.

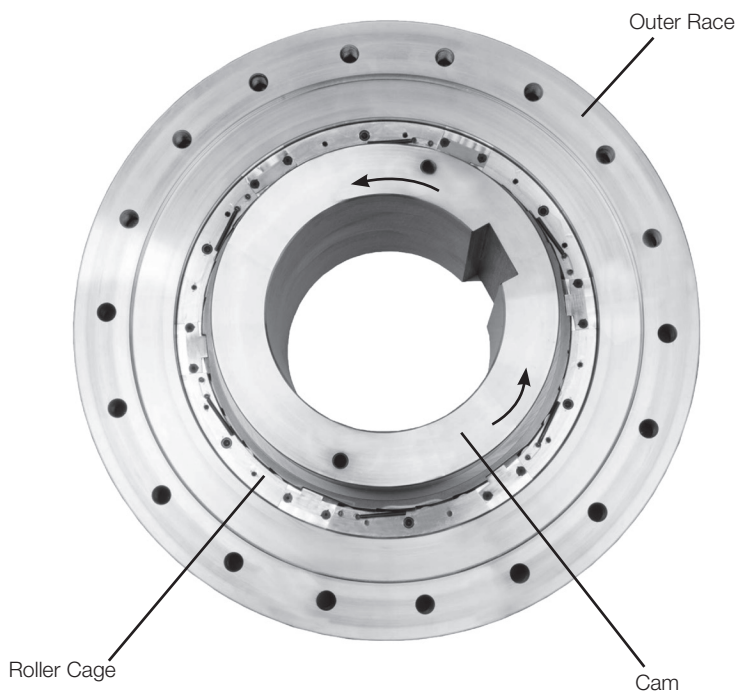

**Illustration 2**

Coverplate and bearing have been removed to show the roller cage that maintains the rollers in their optimal position.

## Shaft Retaining Collar

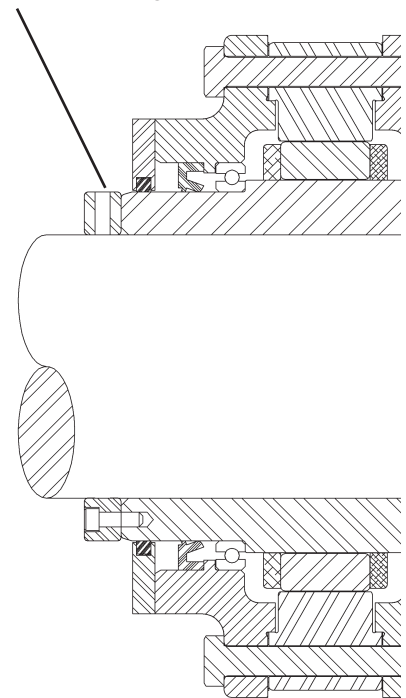

# Design Features

## Design Features

Marland backstops are completely mechanical, automatic operating units, incorporating a time proven basic operating principle, to provide greater safety and longer life with minimum maintenance requirements. Seventeen standard sizes are available up to 1,200,000 pound-feet of torque. Superior performance is assured by the following design features:

**SIMPLE INITIAL INSTALLATION.** Backstop is symmetrical and can be mounted for desired free shaft rotation. Arrows on cam faces or inner labyrinth show the direction of free rotation.

The torque arm is a single "I" beam section which is attached to the backstop with two precision ground torque arm pins. This greatly simplifies field installation. The arm may be placed up, down, or at any angle, and provides uniform loading on both coverplates. The preferred position is horizontal to reduce bearing loading for longer bearing life.

**SEALED OIL CHAMBER.** The Clutch elements and ball bearings are continuously self-oiled in a sealed oil chamber. The recommended lubricant is Mobil DTE Heavy Medium oil for a wide range of ambient temperatures. A double-lip oil seal is provided adjacent to the ball bearings to keep oil in and contaminants out. (See Illustration 3)

**POSITIVE TRIPLE SEALING.**  
(See Illustration 4)

1. All metal labyrinth, grease packed.
2. Full circle square packing against ground inner labyrinth which maintains grease seal and serves as an additional barrier to entry of dirt.
3. Double-lip oil seal to prevent grease from entering oil chamber and oil dilution of sealing grease.

**MINIMUM MAINTENANCE.** Grease fittings in each outer labyrinth are provided for occasional renewal of grease seal which forces out dirt and old grease through relief fittings. A periodic check of oil level and purity can readily be made through oil level indicator while in operation or at rest. If inspection reveals impurities in the oil, draining, flushing and refilling can be easily accomplished through the piping, tees, and drain plugs furnished.

## Special Requirements

In over 70 years as the recognized leader in the design and manufacture of freewheeling clutches, the Marland engineering staff has been given many unusual and difficult requirements for clutches and backstops. This has resulted in special designs to meet those exacting requirements. If your needs cannot be filled by a standard item, give us the engineering details. It may be that we already have a solution to your problem, and if not, we'll go to work and find one.

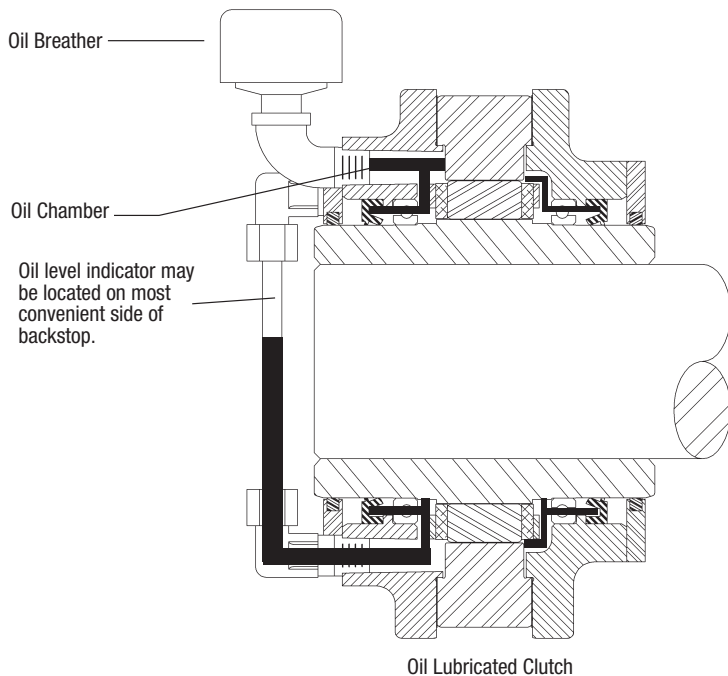

**Illustration 3**

Shows the sealed oil chamber for continuous lubrication of clutch operating parts and ball bearings.

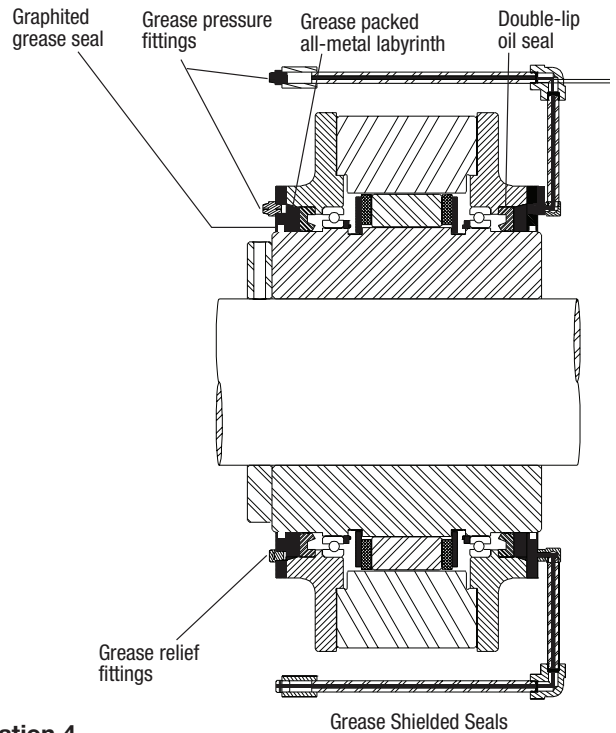

**Illustration 4**

Positive triple sealing of the oil chamber by grease-packed all-metal labyrinth, graphited grease seal and double-lip oil seal.

# Advantages of Marland Cylindrical Rollers on Flat Included Cam Surfaces

## Free Rotation

The cylindrical rollers used in all Marland clutch products are free to rotate in their individual pockets during freewheeling permitting the load to be engaged and re-engaged on any part of the roller circumference and cylinder surface as indicated by the arrows in Illustration 5.

## Longer Service Life

Engagement of the roller under load does not always fall on the same line, zone, or spot to result in spalling or cratering. This results in longer service life for the contacting surfaces.

## Accurate Dimensions

Cylindrical rollers are easy to produce and reproduce to precision dimension limits which are readily checked with micrometers, go-no-go gauges, or if necessary, with the extreme closeness of light band inspection.

## Full Contact

Precision-ground, flat cam areas furnish ideal contacting surfaces for the cylindrical rollers and assure full contact with the entire cylinder length of each roller.

## Lower Stress

When roller and cam are engaged under compressive loading, (Illustration 5), the load is uniformly distributed over a large zone of contact with consequently lower stresses to result in more durable, efficient operation.

Marland Backstops are a complex design that has been optimized to provide a longer operating life with less maintenance. Here are some of the major backstop components and their key design features.

### 1. Cam

High Grade forged alloy steel, deep case hardening, precision machined

- Selected for optimal strength and wear resistance
- Heat treated to values which exceed competition, maximize peak torque capacities

### 2. Roller Assembly

High Grade forged alloy steel, through hardening, precision ground rollers

- Designed to enhance load capacity
- Eliminates backlash
- Minimizes heat generation

### 3. Outer Race

High Grade forged alloy steel, deep case hardening, precision machined, full Section thickness throughout the length of outer race, lower Hoop Stresses leading to greater backstop peak capacity, better load distribution through length of torque transmitting elements, higher torsional stiffness of clutch assembly and less torsional wind-up

### 4. Bearings

Optimized selection for L10 life versus usable shaft requirements

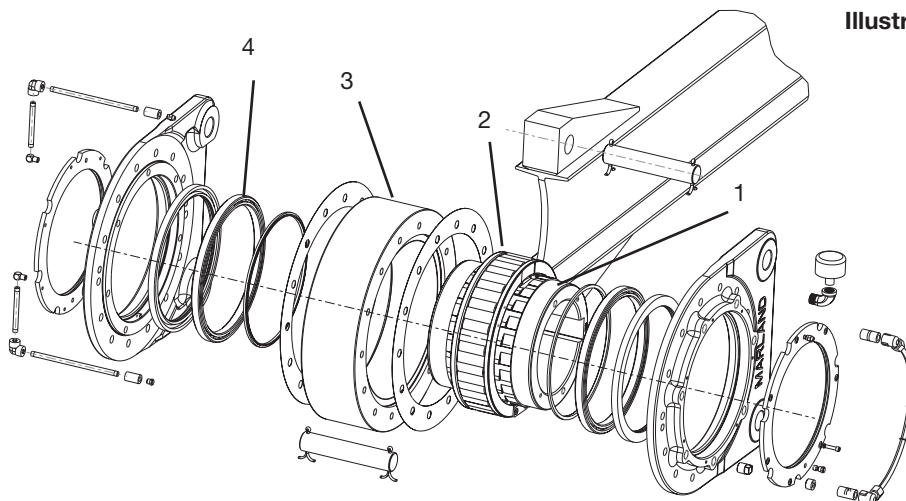

Illustration 5

# Locate Backstops Where Reverse Torque Loads Originate

## Where Reverse Torque Loads Originate

The ideal time to prevent reversal of a loaded inclined conveyor or elevator is at the very instant when forward rotation of the headshaft ceases. Even a small time lag before arresting the backward travel results in a greater effort needed to bring the inclined conveyor to rest and to hold the load.

When high speed shaft backstops are used the amount of time and the distance of reverse motion of the inclined conveyor or elevator before the backstop can become effective, is determined by the accumulated backlash of any gears, couplings, keys, chains, sprockets and shafts in the drive system.

It is obvious that a reversed torque load, further reinforced by any accumulated backlash in the drive system, could result in the failure of any one of these connecting drive components when the reverse torque load is permitted to travel beyond the headshaft where it originated, to reach a backstop installed at some higher speed location in the drive system.

## Locating Backstops on Low-Speed Drive Pulley(s)

Failure of any part of the drive between the head (or drive pulley) shaft, and a high speed shaft backstop can cause a reversed runaway condition. Maximum protection against such reversed runaways can be obtained only when backstops are installed on low speed drive pulley shafts where the reverse torque originates and where such backstops can function instantly, before backlash and reverse motion can occur.

In some installations it may be physically impossible to locate the backstop on the pulley shaft. In these cases, the alternate location could be on the double extended low speed reducer shaft. (See Illustration 6)

Where the design and speed of the equipment will not permit the use of a low speed backstop, refer to Cecon backstop units.

Illustration 6

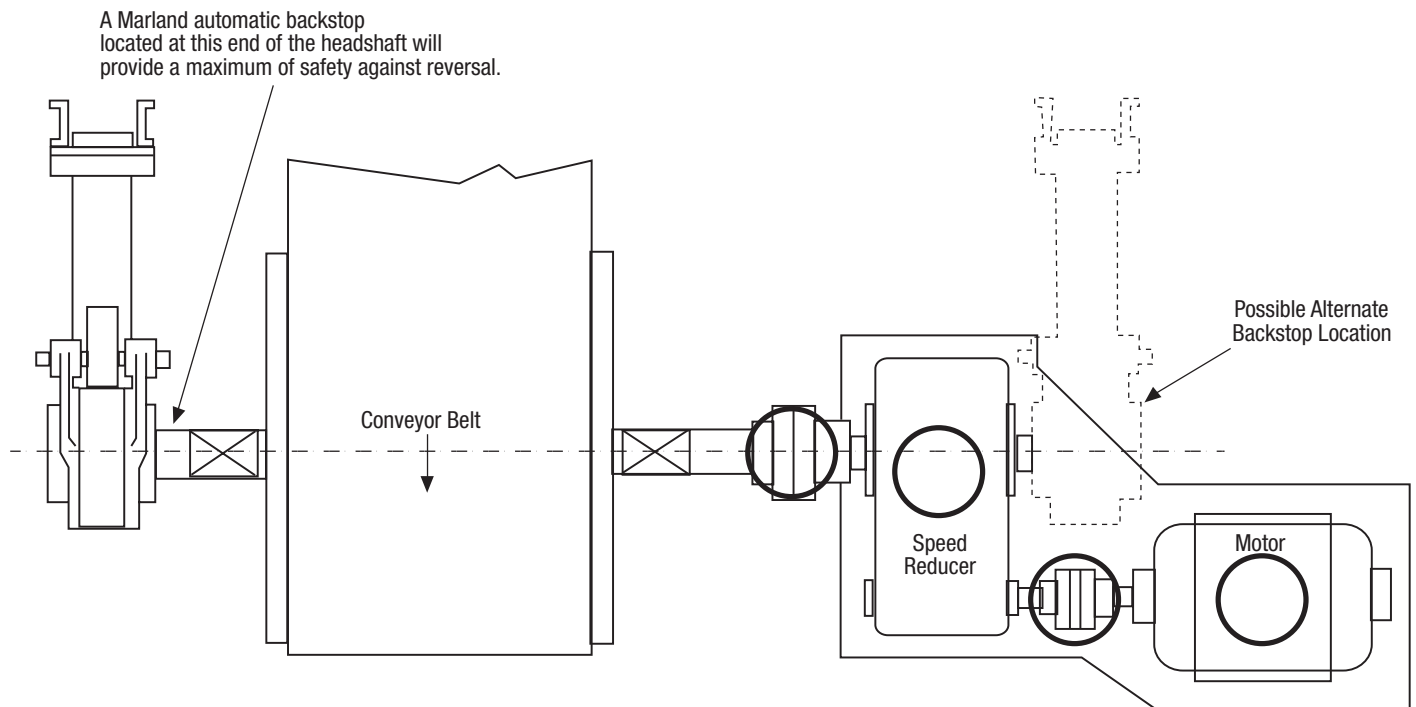

○ Failure may occur at any of these driving parts circled, their keys, the speed reducer, couplings, motor or of electric current, while the inclined conveyor or elevator is heavily loaded. Any motor brake or backstop, located between the motor and the heavily loaded headshaft would be of no value in preventing a reversed runaway.

# Recommended Backstop Locations for Typical Conveyor Arrangements

## Single Drive Pulley

For head pulley driven inclined conveyors or elevators, the backstop should be located on the head pulley drive shaft. With the drive at one end of the head pulley shaft, the backstop should be located at the opposite end, away from the speed reducer and coupling. (See Illustration 7)

For a single drive pulley other than the head pulley, the backstop should be located on the drive pulley shaft, rather than on the head pulley shaft. The head pulley may not have sufficient belt wrap to keep the loaded belt from slipping backward when the backstop prevents reversal of the pulley and its shaft. With the drive at one end of the drive pulley shaft, the backstop should be located at the opposite end, away from the speed reducer and coupling. (See Illustration 8)

When dual drives to a single pulley shaft are used as in Illustration 9, the backstops should be located on the shaft between the low speed couplings and adjacent pulley shaft bearings.

## Tandem Drive Pulleys

Backstops should be located on both primary and secondary drive pulley shafts. Thus the secondary pulley backstop(s) will insure tractive friction on both pulleys. (See Illustration 10)

Primary drive pulley shaft backstops should have capacity equal to the total primary and secondary motor (or motors) normal rating. Secondary drive pulley shaft backstops should have capacity equal to the secondary motors normal rating.

Illustration 7

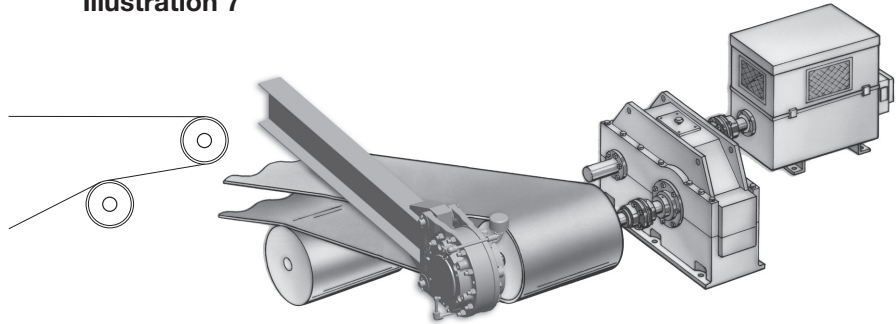

Illustration 8

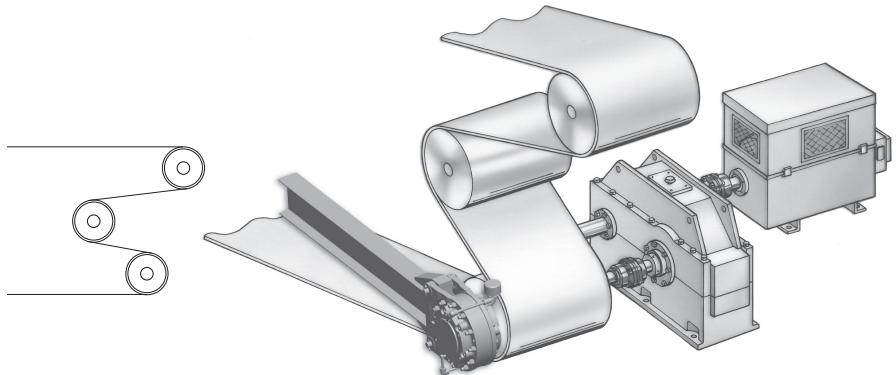

Illustration 9

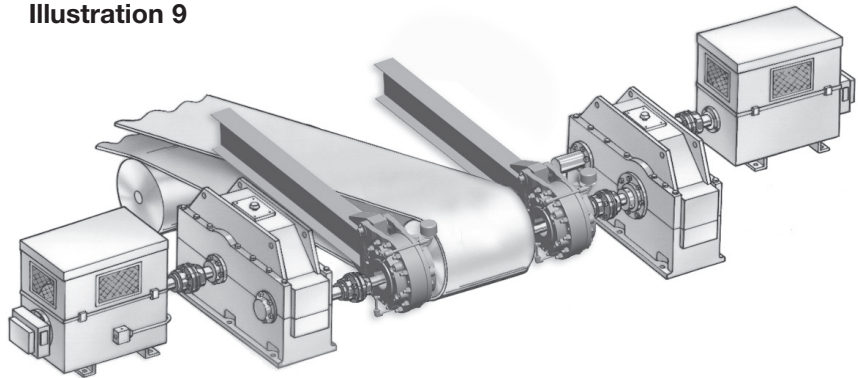
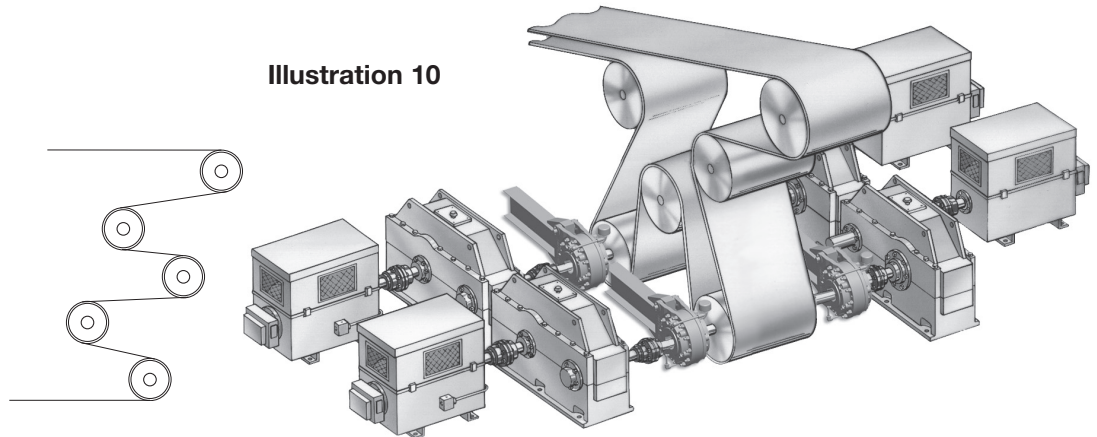

Illustration 10



# Principles of Backstop Size Selection for Low Speed Shafts

---

In the past, the usual basis for determining the size of a backstop included only consideration of calculated lift and frictional loads. In some cases selection was made based on subtraction of all of the frictional load from the lift load to arrive at the net backstop capacity required. Backstops so selected could prove to be of inadequate capacity and could result in very serious and costly damage. More conservative selection was based on subtracting only one-half the frictional load from the lift load. Lift loads were also calculated at the maximum depth “spill load”, rather than at normal or recommended conveyor or elevator values, in an attempt to guard against either an expected or intentional overloading of conveyors and their respective backstops. This method dictated the use of larger backstops which reduced the danger from overloads and resulted in fewer runaways. The more conservative selection procedure could be dangerously misleading where a heavily overloaded or completely stalled motor could develop.

## Improper Feed Adjustment

Where a conveyor or elevator feed is improperly adjusted during initial installation or later regular operation of the equipment, a stalled condition may develop resulting from flooding of the belt or choking of the elevator. During such overloads, electric motors may develop 200 to 250 percent of normal torque rating before they “cut out” by automatic or manual control in order to prevent damage to the motor windings. Such high torque is transmitted from the motor to the drive pulley shaft where it induces a high tension or “rubber band stretch” in the belt. When the motor “cut out” occurs, the “stretched rubber band” effect of the overloaded or stalled belt reacts on the drive pulley to rotate it in reverse. This condition overloads the backstop to the fully stalled motor torque rating, less only the frictional loss of the driving unit between the stalled motor and the headshaft.

## Momentary Starting Under Load

Momentary starting of the drive motor at a time when the stationary belt was already fully loaded to its normal capacity, developed into an overloaded backstop condition. We found that when the motor was so started, stretching the belt so that conveyor motion was just beginning, and at that instant the motor was intentionally cut out, the stored energy in the “rubber band stretch” reacted on the backstop with much greater force than occurs after a fully loaded conveyor comes to a normal stop.

Where an electronic tramp iron detector resulted in such momentary but very frequent stopping and starting condition, the backstop was severely overloaded far beyond the normal motor rating.

## Stalled Conveyors

Even though the conveyor equipment has been in satisfactory operation for some time without overloading, the entry of oversize pieces, timbers or structural scrap, jammed between the bin gate and the belt, could cause the conveyor to stall and overload the motor as noted under improper feed adjustment. Under these conditions the backstops could be overloaded much beyond what would ordinarily be the calculated lift or reverse torque loads.

## Other Motor Overloading

Studies further showed that conveyor belts also can be stalled due to improper setting of skirt boards, misaligned pulley and idlers. To properly handle such conditions, selection of the backstop should be based on the maximum possible motor overload rather than on the normal belt loading theoretical calculations.

## Optional Engineered Solutions

### Installation Solutions

- Special cam of keyless fits
- Special torque arm lengths

### Maintenance-Monitoring

- Automatic Greasers
- Modifications to backstop for mounting of monitoring equipment
- Special sealing arrangements

### Systems Solutions

- Various types of load sharing systems based on customer requirements



# How to Select a Marland Backstop

## General

Backstop selection is based on stalled torque rating of the driving motor to provide for the conditions when overloaded motor “cut-out” may occur and the “stretched rubber band” effect of the stalled belt would react on the pulley to rotate it in reverse against the non-reversing backstop.

The preferred mounting of backstops is directly onto the drive pulley shaft whether headshaft or intermediate shaft. For some typical arrangements and recommended backstop locations (See Page 6)

## Backstop Size Selection Based on Breakdown or Stalled Torque Rating of Driving Motor

### Step 1 — Calculate torque

Multiply the nameplate motor horsepower(kw) rating by 5250 (9550 metric), then divide the result by the RPM of the low speed drive pulley shaft on which the backstop should be mounted. This determines the pound-feet (N-m) torque which is the basis of backstop ratings.

### Step 2 — Service factor to be used

Multiply the value obtained in Step 1 by the proper factor for the driving motor shown in Table B (factors are based on the maximum stalled torque percent of the normal motor rating). The result will be the minimum required torque capacity which is to be used when referring to the rating table.

### Step 3 — Select the Marland Backstop

Refer to Page 10 and select the size of Backstop with a rated torque equal to or greater than the calculated torque.

Check backstop RPM to see whether it is within the listed catalog maximum RPM. If greater, consult Home Office.

Check shaft diameter to see whether it is within the backstop bore limits. If the shafts are too large, a larger size backstop may be selected, or if preferred, shafts may be turned down to accommodate maximum bore for selected backstop.

In all cases, calculate the resulting stress and check conformance of shafting with the applicable design codes.

## Ordering Information

When ordering or requesting size selection from Home Office, the following information should be included:

1. Horsepower (kw) of driving motor(s) and maximum stalled torque percent of normal motor rating.
2. RPM of shaft on which backstop is to be mounted.
3. Shaft diameter and keyway size at backstop location.
4. Profile drawing of system and/or general arrangement drawing (if available).

**TABLE “B”**

### Maximum Breakdown or Stalled Torque

% of Normal Motor Rating	Service* Factor
175%	1.00
200%	1.15
225%	1.30
250%	1.50

\* All Marland Backstops can handle a peak overload torque of 1.75 times the catalog rating.

## ENGLISH

### Example of Selection Procedure

Required backstop for mounting on drive pulley shaft rotating at 55 RPM, driven by a 150 HP motor having a maximum stalled torque rating at 200% of normal:

### Step 1

$$\frac{150 \times 5,250}{55} = 14,318 \text{ lb.ft.}$$

### Step 2

14,318 x 1.15 (service factor) equals 16,466 lb.ft.

### Step 3

From tabulated rating on Page 11, proper backstop selection is the BC-18MA, rated 18,000 lb.ft., with maximum bore 5-7/16". If drive pulley shaft exceeds this maximum, it will be necessary that shaft be turned to suit, or that the next larger backstop be used.

## METRIC

### Example of Selection Procedure

Required backstop for mounting on drive pulley shaft rotating at 55 RPM, driven by a 150 KW motor having a maximum stalled torque rating at 200% of normal:

### Step 1

$$\frac{150 \times 9,550}{55} = 26,045 \text{ N-m}$$

### Step 2

26,045 x 1.15 (service factor) equals 29,952 N-m

### Step 3

From tabulated rating on Page 10, proper backstop selection is the BC-27MA, rated 36,607 N-m, with maximum bore 165 mm. If drive pulley shaft exceeds this maximum, it will be necessary that shaft be turned to suit, or that the next larger backstop be used.

**Note:** Consult factory for Size Selection for Dual Drive or Tandem Pulley Drives.

# Marland Backstops Type BC MA<sup>®</sup> 3-18

- |   |                 |    |                     |
|---|-----------------|----|---------------------|
| 1 | Coverplate      | 7  | Cam                 |
| 2 | Gasket          | 8  | Pin and Cotter Keys |
| 3 | Ball Bearing    | 9  | Torque Arm          |
| 4 | Oil Seal        | 10 | Outer Labyrinth     |
| 5 | Outer Race      | 11 | Grease Seal         |
| 6 | Roller Assembly |    |                     |

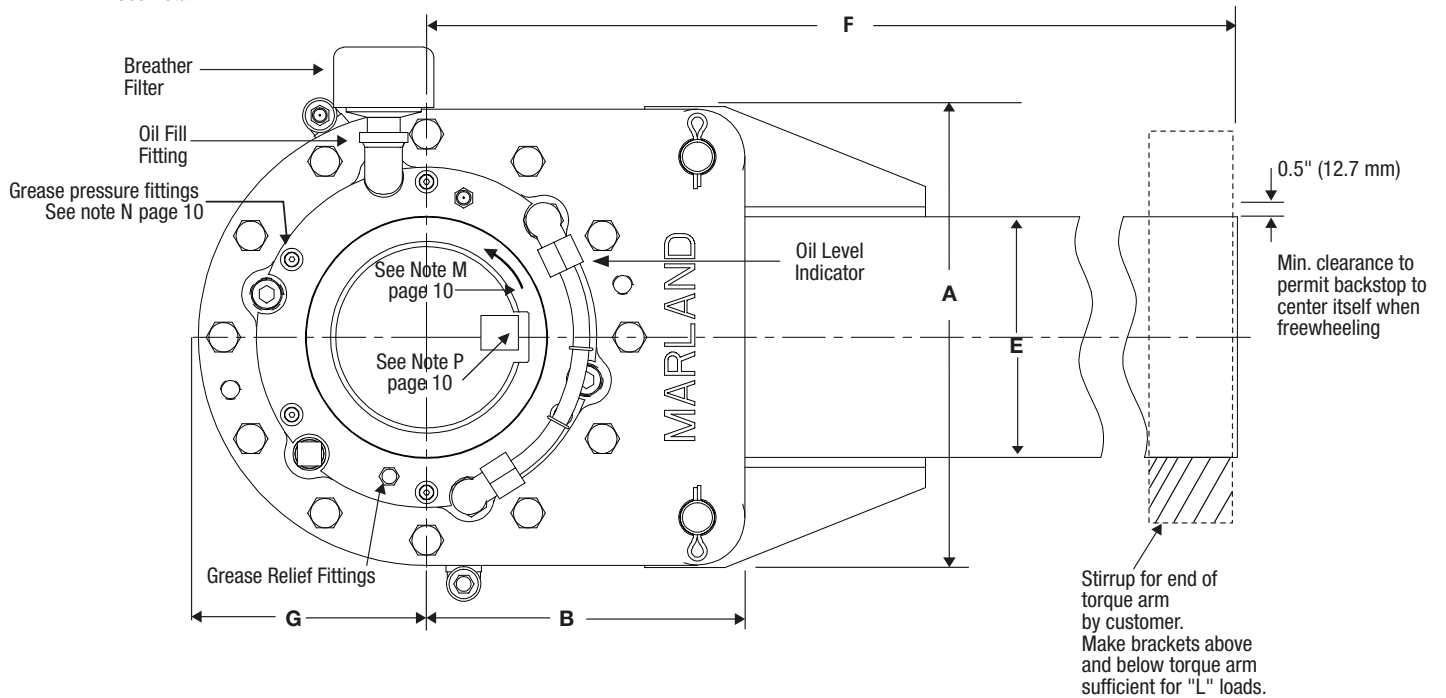
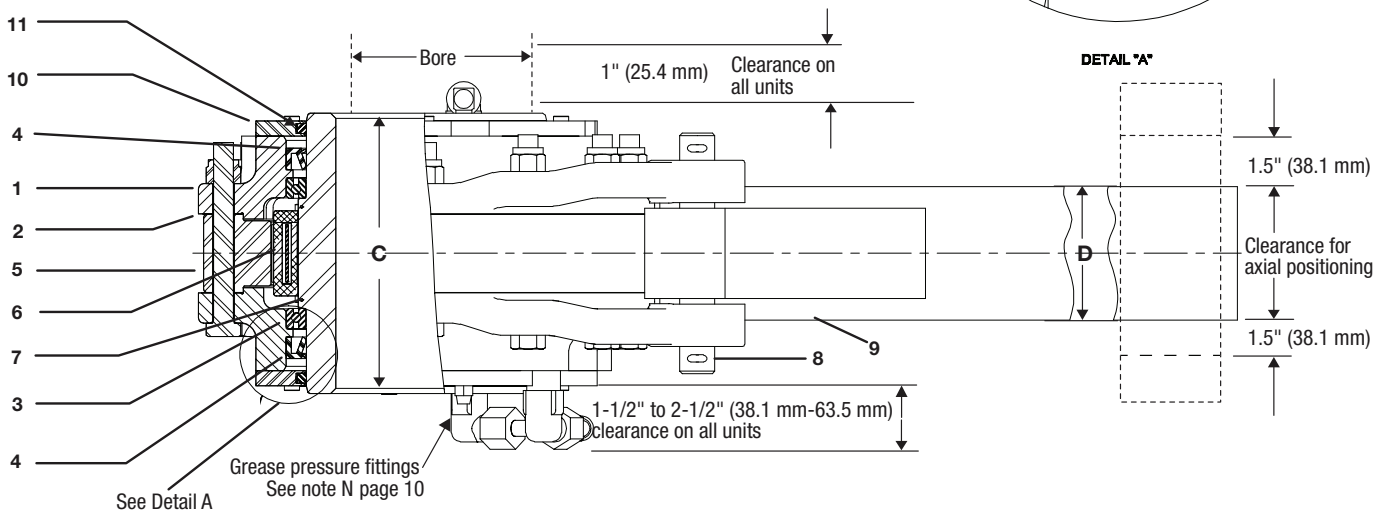
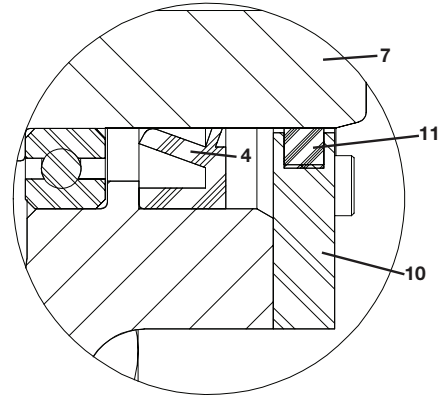

# Dimensions and Data

The torque arm end must not be rigidly attached to steel framework. The bracket or stirrup for the end of the torque arm must provide clearance to permit the backstop to center itself in axial and angular positions to prevent pinching of bearings and damage or failure of unit, and must be sufficient for "L" loads above and below torque arm for backstop size selected. The preferred position is horizontal to reduce bearing loading for longer bearing life. Refer to certified drawings and instruction bulletins furnished with each order.

**Note:** M - Backstop is symmetrical and can be mounted for desired rotation. Arrow on cam face or inner labyrinth indicates direction of free shaft rotation. Before mounting on shaft, be sure to check direction of free rotation.

**Note:** N - Labyrinth seals only are factory packed with grease. Before placing in operation, backstop must be filled internally with recommended oil.

**Note:** P - When installed, backstop must be restrained from the possibility of axial movement on the shaft by one of the

following:

1. Retention collar
2. Retention key
3. Keeper plate
4. Drive tight cam key

\*Keys are furnished for all units supplied with maximum bores. Other bore and key sizes are available meeting metric, AGMA and USA standards as well as custom design requirements. Marland has, on the shelf, many of the popular USA standard sizes for customer convenience.

## Engineering Data

Backstop Size	Torque N-m	Rated Torque lb. ft.	Max RPM	Load "L" Kgs.	Load "L" lbs.	Max.* Bore mm	Max.* Bore in.	Max.* Bore Keyway mm	Max.* Bore Keyway in.	Ship Weight Kgs.	Ship Weight lbs.
0003MA	4067	3,000	300	510	1,120	75	2.94	20 x 4.9	.75 x .25	46	100
0006MA	8135	6,000	250	920	2,000	95	3.69	25 x 5.4	.88 x .31	69	150
0012MA	16270	12,000	210	1325	2,880	115	4.50	32 x 7.4	1.00 x .38	100	220
0018MA	24405	18,000	180	1776	3,860	140	5.44	36 x 8.4	1.25 x .44	152	330

## Dimensions

Backstop Size	A		B		C		D		E		F		G	
	mm	in.	mm	in.	mm	in.	mm	in.	mm	in.	mm	in.	mm	in.
0003MA	210	8.25	143	5.62	146	5.75	64	2.50	76	3	813	32	105	4.12
0006MA	248	9.75	165	6.50	169	6.62	70	2.75	102	4	914	36	124	4.87
0012MA	292	11.50	203	8.00	178	7.00	83	3.25	127	6	1270	50	146	5.75
0018MA	343	13.50	235	9.25	189	7.44	92	3.62	152	6	1422	56	168	6.6

## Set Collars

Marland recommends that all backstops be axially restrained on the shaft to prevent the reaction end of the torque arm from imposing biasing loads on the backstop bearings, which can significantly reduce bearing B-10 life.

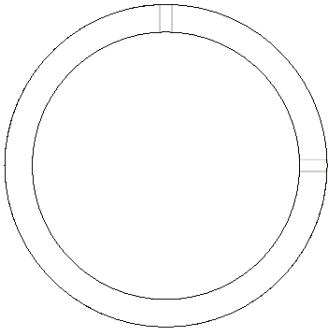

33-1  
444-1

# Marland Backstops Type BC MA 27-180

- |                   |                       |
|-------------------|-----------------------|
| 1 Coverplate      | 7 Cam                 |
| 2 Gasket          | 8 Pin and Cotter Keys |
| 3 Ball Bearing    | 9 Torque Arm          |
| 4 Oil Seal        | 10 Outer Labyrinth    |
| 5 Outer Race      | 11 Grease Seal        |
| 6 Roller Assembly |                       |

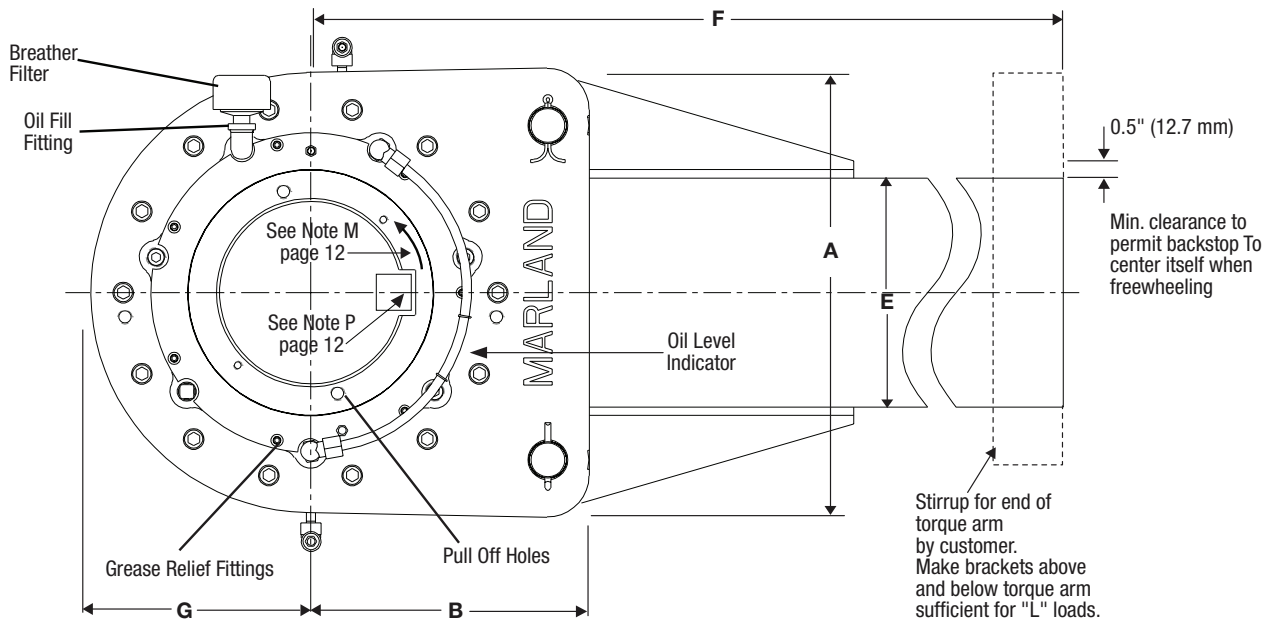
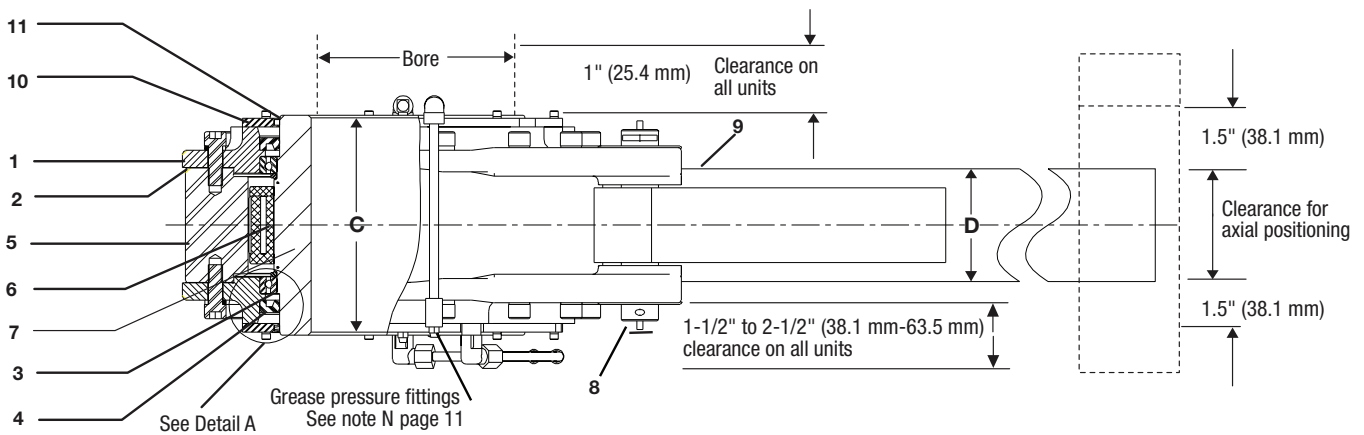
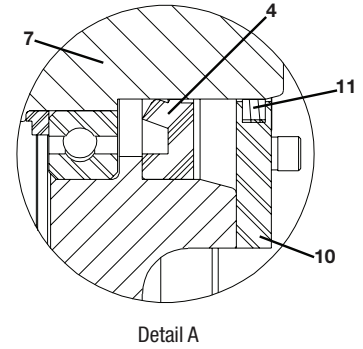

# Dimensions and Data

The torque arm end must not be rigidly attached to steel framework. The bracket or stirrup for the end of the torque arm must provide clearance to permit the backstop to center itself in axial and angular positions to prevent pinching of bearings and damage or failure of unit, and must be sufficient for "L" loads above and below torque arm for backstop size selected. The preferred position is horizontal to reduce bearing loading for longer bearing life. Refer to certified drawings and instruction bulletins furnished with each order.

**Note:** M - Backstop is symmetrical and can be mounted for desired rotation. Arrow on cam face or inner labyrinth indicates direction of free shaft rotation. Before mounting on shaft, be sure to check direction of free rotation.

**Note:** N - Labyrinth seals only are factory packed with grease. Before placing in operation, backstop must be filled internally with recommended oil.

**Note:** P - When installed, backstop must be restrained from the possibility of axial movement on the shaft by one of the following:

1. Retention collar
2. Retention key
3. Keeper plate
4. Drive tight cam key

\*Keys are furnished for all units supplied with maximum bores. Other bore and key sizes are available meeting metric, AGMA and USA standards as well as custom design requirements. Marland has, on the shelf, many of the popular USA standard sizes for customer convenience.

## Engineering Data

Backstop Size	Torque N-m	Rated Torque lb. ft.	Max RPM	Load "L" Kgs	Load "L" lbs.	Max.* Bore mm	Max.* Bore in.	Max.* Bore Keyway mm	Max.* Bore Keyway in.	Ship Weight Kgs.	Ship Weight lbs.
0027MA	36607	27,000	150	2259	4,910	165	6.50	40 x 9.4	1.50 x .50	207	450
0045MA	61012	45,000	135	3450	7,500	180	7	45 x 10.4	1.75 x .56	276	600
0063MA	85417	63,000	120	4462	9,700	205	8	50 x 11.4	2.00 x .69	381	830
0090MA	122024	90,000	105	6072	13,200	235	9	56 x 12.4	2.50 x .75	520	1,130
0135MA	183035	135,000	90	8464	18,400	265	10	63 x 12.4	2.50 x .87	690	1,500
0180MA	244047	180,000	80	10580	23,000	300	11.75	70 x 14.4	3.00 x 1.00	966	2,100

## Dimensions

Backstop Size	A		B		C		D		E		F		G	
	mm	in.	mm	in.	mm	in.	mm	in.	mm	in.	mm	in.	mm	in.
0027MA	384	15.12	254	10.00	222	8.75	98	3.87	178	7	1676	66	191	7.50
0045MA	445	17.50	289	11.37	235	9.25	105	4.12	203	8	1829	72	216	8.50
0063MA	498	19.62	311	12.25	244	9.62	127	5.00	254	10	1981	78	244	9.62
0090MA	584	25.75	362	14.25	276	10.87	140	5.50	305	12	2083	82	270	10.62
0135MA	654	30.37	406	16.00	314	12.37	143	5.62	381	15	2235	88	308	12.12
0180MA	772	34.50	419	16.50	330	13.00	159	6.25	457	18	2388	94	349	13.75

## End Covers

Marland offers end cover kits that provide not only the stationary cover enclosure required by OSHA, but also provides additional protection for the clutch from abrasive environments as well.

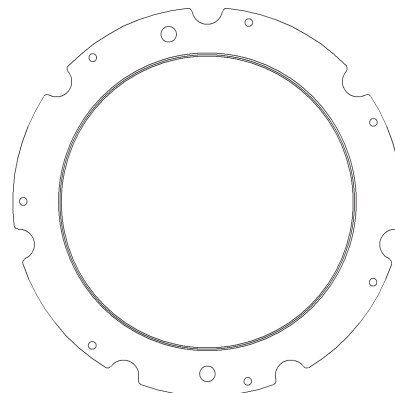
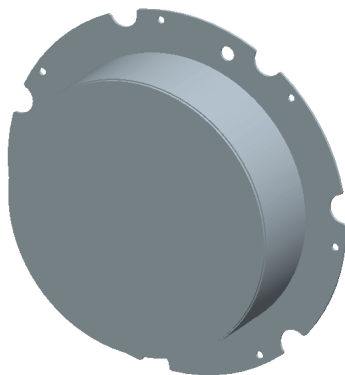

# Marland Backstops Type BC MA 240-1200

- |                   |                       |
|-------------------|-----------------------|
| 1 Coverplate      | 7 Cam                 |
| 2 Gasket          | 8 Pin and Cotter Keys |
| 3 Bearing         | 9 Torque Arm          |
| 4 Oil Seal        | 10 Outer Labyrinth    |
| 5 Outer Race      | 11 Grease Seal        |
| 6 Roller Assembly |                       |

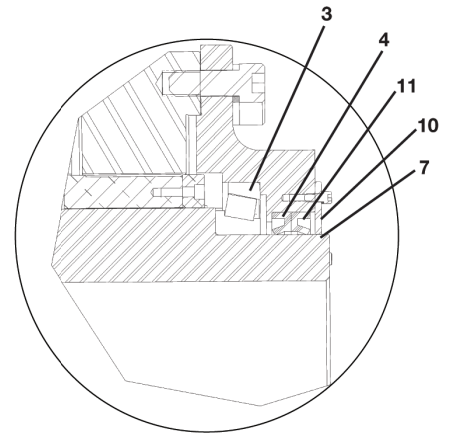

Detail A

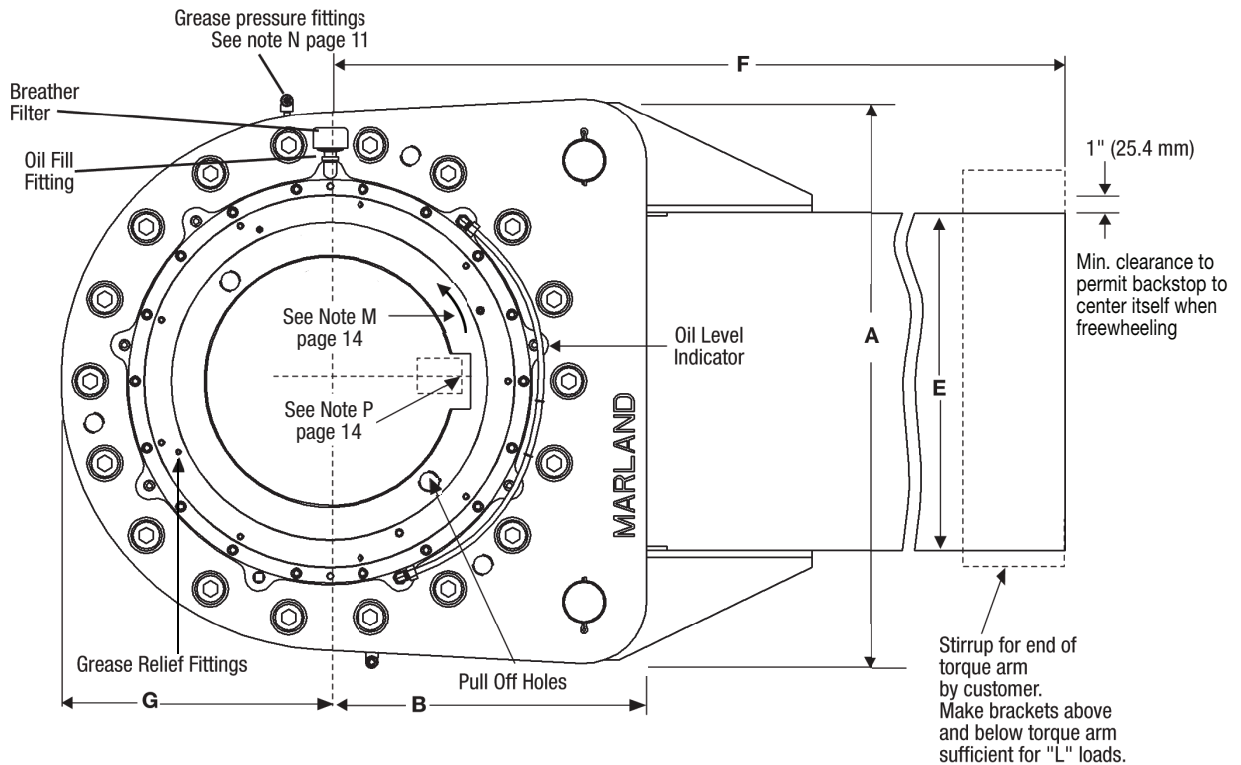
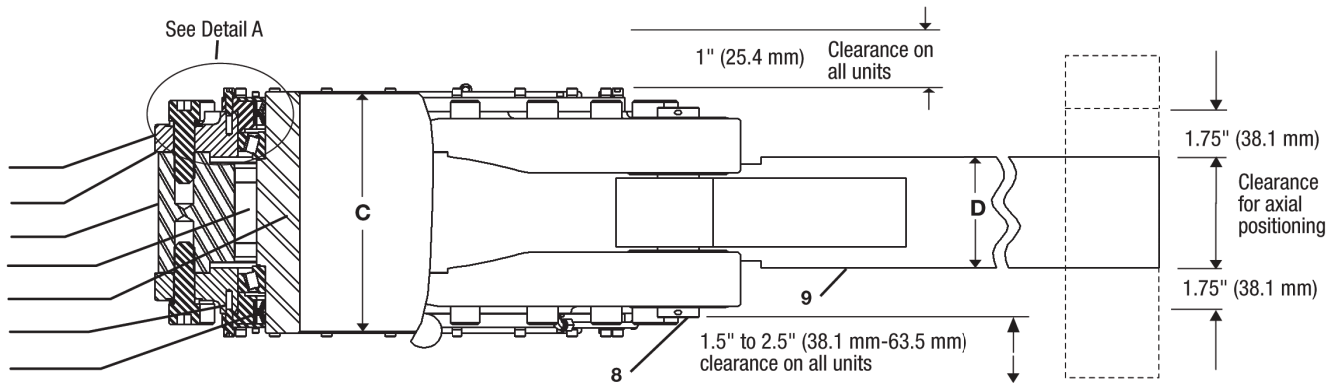

# Dimensions and Data

The torque arm end must not be rigidly attached to steel framework. The bracket or stirrup for the end of the torque arm must provide clearance to permit the backstop to center itself in axial and angular positions to prevent pinching of bearings and damage or failure of unit, and must be sufficient for "L" loads above and below torque arm for backstop size selected. The preferred position is horizontal to reduce bearing loading for longer bearing life. Refer to certified drawings and instruction bulletins furnished with each order.

Note: M - Backstop is symmetrical and can be mounted for desired rotation. Arrow on cam face or inner labyrinth indicates direction of free shaft rotation. Before mounting on shaft, be sure to check direction of free rotation.

Note: N - Labyrinth seals only are factory packed with grease. Before placing in operation, backstop must be filled internally with recommended oil.

Note: P - When installed, backstop must be restrained from the possibility of axial movement on the shaft by one of the following:

1. Retention collar
2. Retention key
3. Keeper plate
4. Drive tight cam key

\*Keys are furnished for all units supplied with maximum bores. Other bore and key sizes are available meeting metric, AGMA and USA standards as well as custom design requirements. Marland has, on the shelf, many of the popular USA standard sizes for customer convenience.

## Engineering Data

Backstop Size	Torque N-m	Rated Torque lb. ft.	Max RPM	Load "L" Kgs	Load "L" lbs.	Max.* Bore mm	Max.* Bore in.	Max.* Bore Keyway mm	Max.* Bore Keyway in.	Ship Weight Kgs.	Ship Weight lbs.
0240MA	325396	240,000	70	13248	28,800	360	14	80 x 15.4	3.50 x 1.00	1242	3,100
0300MA	406745	300,000	70	15180	33,400	360	14	80 x 15.4	3.50 x 1.00	1720	3800
0375MA	508432	375,000	60	17250	37,500	460	18	100 x 19.4	4.50 x 1.50	2760	6,000
0540MA	732142	540,000	60	20460	45,000	540	21	100 x 21.4	5.0 x 1.75	4140	9,000
0720MA	976271	720,000	60	27280	60,000	540	21	100 x 21.4	5.0 x 1.75	4545	10,000
0940MA	1274600	940,000	60	32870	72,400	540	21	100 x 21.4	5.0 x 1.75	5455	14,000
01200MA	1626000	1,200,000	60	39100	86,000	600	23.50	TBD	TBD	6591	14,500

## Dimensions

Backstop Size	A		B		C		D		E		F		G	
	mm	in.	mm	in.	mm	in.	mm	in.	mm	in.	mm	in.	mm	in.
0240MA	876	34.50	457	18	387	15.25	162	7.06	508	20.25	2540	100	413	16.25
0300MA	876	34.50	457	18	413	16.25	162	7.06	508	20.25	2745	108	413	16.25
0375MA	1041	41	584	23	445	17.50	203	8	622	24.25	3048	120	495	19.50
0540MA	1194	47	673	26.50	527	20.75	257	10.12	692	27.25	3658	144	578	22.75
0720MA	1194	47	673	26.50	552	21.75	257	10.12	692	27.25	3658	144	578	22.75
0940MA	1320	52	750	29.50	584	23.00	267	10.50	762	30.00	3960	156	660	26.0
1200MA	1320	52	750	29.50	625	24.62	267	10.50	762	30.00	4267	168	660	26.0

## Rotating Equipment

Rotating equipment is potentially dangerous and should be properly guarded. The user should check for all applicable safety codes (in local area) and provide a suitable guard. Marland backstops have surfaces which wear with use over time and as a result will need to be replaced. The decision for time of replacement must be made by the operator of the equipment based upon the specific application and performance of the clutch or backstop.

## Catalog Changes

The contents of this catalog are subject to change without notice or obligation.

All Customer Service phone numbers shown in bold

## Electromagnetic Clutches and Brakes

### Warner Electric

*Electromagnetic Clutches and Brakes*

New Hartford, CT - USA  
1-800-825-6544

*For application assistance:*  
1-800-825-9050

St Barthelemy d'Anjou, France  
+33 (0) 2 41 21 24 24

*Precision Electric Coils and Electromagnetic Clutches and Brakes*

Columbia City, IN - USA  
1-260-244-6183

### Matrix International

*Electromagnetic Clutches and Brakes, Pressure Operated Clutches and Brakes*

Brechin, Scotland  
+44 (0) 1356 602000

New Hartford, CT - USA  
1-800-825-6544

### Inertia Dynamics

*Spring Set Brakes, Power On and Wrap Spring Clutch/Brakes*

New Hartford, CT - USA  
1-800-800-6445

## Linear Products

### Warner Linear

*Linear Actuators*

Belvidere, IL - USA  
1-800-825-6544

*For application assistance:*  
1-800-825-9050

St Barthelemy d'Anjou, France  
+33 (0) 2 41 21 24 24

## Couplings

### Ameridrives Couplings

*Mill Spindles, Ameriflex, Amerisc*

Erie, PA - USA  
1-814-480-5000

*Gear Couplings*

San Marcos, TX - USA  
1-800-458-0887

### Bibby Turboflex

*Disc, Gear, Grid Couplings, Overload Clutches*

Dewsbury, England  
+44 (0) 1924 460801

Boksburg, South Africa  
+27 11 918 4270

### TB Wood's

*Elastomeric Couplings*

Chambersburg, PA - USA  
1-888-829-6637 – Press #5

*For application assistance:*  
1-888-829-6637 – Press #7

*General Purpose Disc Couplings*

San Marcos, TX - USA  
1-888-449-9439

### Ameridrives Power Transmission

*Universal Joints, Drive Shafts, Mill Gear Couplings*

Green Bay, WI - USA  
1-920-593-2444

### Huco Dynatork

*Precision Couplings and Air Motors*

Hertford, England  
+44 (0) 1992 501900

Chambersburg, PA - USA  
1-800-829-6637

### Lamiflex Couplings

*Flexible Couplings, Bearing Isolators, and Coupling Guards*

São Paulo, SP - Brasil  
(11) 5679-6533

## Heavy Duty Clutches and Brakes

### Wichita Clutch

*Pneumatic Clutches and Brakes*

Wichita Falls, TX - USA  
1-800-964-3262

Bedford, England  
+44 (0) 1234 350311

### Twiflex Limited

*Caliper Brakes and Thrusters*

Twickenham, England  
+44 (0) 20 8894 1161

### Industrial Clutch

*Pneumatic and Oil Immersed Clutches and Brakes*

Waukesha, WI - USA  
1-262-547-3357

## Gearing

### Boston Gear

*Enclosed and Open Gearing, Electrical and Mechanical P.T. Components*

Charlotte, NC - USA  
1-800-825-6544

*For application assistance:*  
1-800-816-5608

### Bauer Gear Motor

*Geared Motors*

Esslingen, Germany  
+49 (711) 3518 0  
Somerset, NJ - USA  
1-732-469-8770

### Nuttall Gear and Delroyd Worm Gear

*Worm Gear and Helical Speed Reducers*

Niagara Falls, NY - USA  
1-716-298-4100

## Overrunning Clutches

### Formsprag Clutch

*Overrunning Clutches and Holdbacks*

Warren, MI - USA  
1-800-348-0881 – Press #1

*For application assistance:*  
1-800-348-0881 – Press #2

### Marland Clutch

*Roller Ramp and Sprag Type Overrunning Clutches and Backstops*

South Beloit, IL - USA  
1-800-216-3515

### Stieber Clutch

*Overrunning Clutches and Holdbacks*

Heidelberg, Germany  
+49 (0) 6221 30 47 0

## Belted Drives and Sheaves

### TB Wood's

*Belted Drives*

Chambersburg, PA - USA  
1-888-829-6637 – Press #5

*For application assistance:*  
1-888-829-6637 – Press #7

## Engineered Bearing Assemblies

### Kilian Manufacturing

*Engineered Bearing Assemblies*

Syracuse, NY - USA  
1-315-432-0700

For information concerning our sales offices in Asia Pacific check our website  
[www.altramotion.com.cn](http://www.altramotion.com.cn)



[www.marland.com](http://www.marland.com)

449 Gardner Street  
South Beloit, IL 61080 - USA  
815-389-7797  
Fax: 815-389-7628